

RECOMMENDED PC BOARD PATTERN DIM. (REF.)

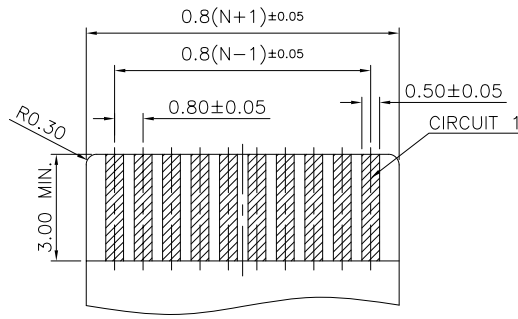

APPLICABLE FPC (THICKNESS: 0.3±0.03)

NOTES:

1. MATERIAL:

- 1.1 HOUSING: THERMOPLASTIC, HIGH TEMP.,UL94V-0; COLOR:NATURAL.
- 1.2 ACTUATOR: THERMOPLASTIC, HIGH TEMP.,UL94V-0; COLOR:BLACK.
- 1.3 CONTACT: COPPER ALLOY
- 1.4 FITTING NAIL: COPPER ALLOY

2. FINISH:

- 2.1 CONTACT:50u" MIN. NICKEL PLATING OVERALL, 1: GOLD FLASH PLATING ON CONTACT AND SOLDER AREA; N: 80~150u" MATT TIN PLATING
- 2.2 FITTING NAIL:50u" MIN. NICKEL UNDERPLATING OVERALL, 100~200u" MATT TIN PLATING.
- 3. REFLOW SOLDER CAPABLE TO 260°C PER ACES SPEC.
- 4. SPEC. PLS. REFER TO PS-51591-XXXXX-XXX.
- 5. PACKAGE PLS. REFER TO 51591-XXXXX-00-TRP.
- 6. PART NUMBER

51591-XXX X X-XXX

NO OF CKT

PACKING
0: TAPE & REEL

	HOUSING MATERIAL&COLOR	ACTUATOR MATERIAL&COLOR	HALOGEN FREE
001	HF & NATURAL	HF & BLACK	HF

PLATING

1: GOLD FLASH PLATING ON CONTACT AND SOLDER AREA
N: MATT TIN

CKT	Dim A	Dim B	Dim C	Dim D
24	18.40	24.10	20.06	20.30
30	23.20	28.90	24.86	25.10

一般公差 TOLERANCES X ±0.50 XX ±0.15 X ±0.25 XXX ±0.10 ANGLES ±2°		宏致電子股份有限公司 Aces Electronics Co.,Ltd.	
檢驗尺寸標示 SYMBOLS INDICATE CLASSIFICATION DIMENSION MARK IS CRITICAL DIM. MARK IS MAJOR DIM.		品名 (TITLE) 0.8 PITCH EASY ON FPC CONN H=1.5mm SMT R/A TYPE 圖號 (DWG NO.) 51591-XXXXX-XXX	
表面處理 (FINISH)		比例 (SCALE) 5:1 單位 (UNITS) mm	
製圖 (DR) TANGENHUI 16'/02/17 審核 (CHKD) ANDREW 核准 (APPD) CHARLESLEE		張數 (SHEET) 1 OF 1 SIZE A4 REV A	